

Composite Coatings to Improve Durability of the Working Body of the Drill

Mara Kandeveva¹⁾, Stefan Stoenchev³⁾, Vyara Pozhidaeva^{2)*}, Dimitar Karastoyanov³⁾ and Juliana Javorova⁴⁾

¹⁾Technical University-Sofia, Faculty of Industrial Engineering, Tribology Center, 8, Blvd. Kl. Ohridski, 1156 Sofia, Bulgaria

²⁾University of Mining and Geology, St. Ivan Rilski, 1700 Sofia, Bulgaria

³⁾Institute for Information and Communication Technologies, Bulgarian Academy of Sciences, „Acad. G. Bonchev” St., 1113 Sofia, Bulgaria

⁴⁾University of Chemical Technology and Metallurgy, 8 Kliment Ohridski Blvd., 1756 Sofia, Bulgaria

*Corresponding author: vpojidaeva@abv.bg

1. Introduction

Working bodies of drilling machines in the mining industry are subject to heavy wear. The mechanisms and rate of wear depend on many factors - dynamic load with or without impact, abrasive properties - solid or lose, aggressive working ambience, etc. [1], [2], [3].

This work is dedicated to the study and research of the opportunities for improving the resource of the working body of machines and tools through applying wear-resistant composite coatings by on super advanced technologies - high velocity oxy-fuel coating spraying (HVOF).

HVOF is one of the modern methods in tribotechnologies for coating deposition by thermal spraying process. It is a super-sound flame spraying process, where oxygen and combustion gas: propane, propylene or hydrogen, are used under high pressure. The gas flame mixture is accelerated to super-sound velocity and the powder source coating material is injected in the flame. The powder particles are being cooled at the impact with the substrate surface; they pile up in layers and form the laminar structure of the deposited coating.

The HVOF-technology minimizes the used thermal energy and maximizes the kinetic energy of the particles causing formation of coatings with high density, low porosity and high adhesion strength.

The obtained HVOF-coatings of super-alloys are very important and irreplaceable when applied for operation under conditions of high abrasion, erosion and cavitations [4].

The paper aims a comparative study of abrasive wear and wear-resistance of HVOF-coatings deposited using four powder compositions.

2. Materials and technologies

The studied HVOF-coatings were with different matrices: iron (Fe), nickel (Ni), tungsten (W) and (Al_2O_3). The coatings were deposited on steel substrate with chemical content given in Table 1.

Table 1: Chemical content of specimens' substrate

Chemical content, wt %							
C	S	Mn	P	Si	Cr	Ni	Fe
0.40	0.045	0.55	0.045	0.20	0.30	0.30	Balance

Powder compositions were used for the application of the coatings, containing various elements in percents given in Table 2. The average size of the powder particles was 35 μm .

Table 2: Chemical content of powder compositions

№	Powder composition	Composition %	Hardness HRC
0		Without coating	
1	80M60	0,15C;0,21Si;0,8Mn;0,011P; 0,025S Ni balance	60-62
2	F382F	17,3Cr; 2,2Mo;0,019C; 0,009S; 0,02P; 0,9Si; Mn<0,3 Fe balance	25-30
3	WC/Co (88/12)	12Co; 5,4C; Fe<0,1; Ni<0,1 W balance	68-70
4	$Al_2O_3+TiO_2$	60 Al_2O_3 ; 40 TiO_2	58-60

All coatings were prepared with equal roughness $Ra = 0,418 \mu m$ measured by TESA Rugosurf 10G and with equal thickness $h_0 = 240 \mu m$. The thickness was measured by Pocket-LEPTOSKOP.

A system of make MICRO-JET POWDER TM 2000 for super-sound deposition of coatings was used in the experimental work at equal parameters of the technological regime given in Table 3.

Table 3: Parameters of the technological regimes at the studied coating deposition

№	Parameter	Technological regime
1.	Propylene/oxygen ratio %	55/100
2.	Jet velocity, m/s	1000
3.	Distance „nozzle-coating” L, mm	120
4.	Angle between nozzle and coating, α , grad	90
5.	Air pressure from compressor, bar	5
6.	N_2 pressure in the proportioning device, bar	4
7.	Velocity of powder material feeding, tr/min	1,5
8.	Mass flow rate of the powder material, g/min	22

3. Experimental procedure

Abrasive wear of the obtained coatings is studied through the apparatus according to the kinematic scheme “pin-on-drum” shown as functional arrangement in Fig. 1.

The device consists of vertical cylindrical specimen 2 with coating, which contacts butt-to-butt of its surface 4 and the abrasive surface 5 of the counter-body in the form of cylindrical drum 1.

The specimen 2 is fixed to the loading head 6 through the elastic link, which allows self-adjustment of the specimen 2 to the surface 5 of the drum 1 and its possibility for rotation around its own vertical axis. All this provides regular wear of the whole nominal contact area of the specimen.

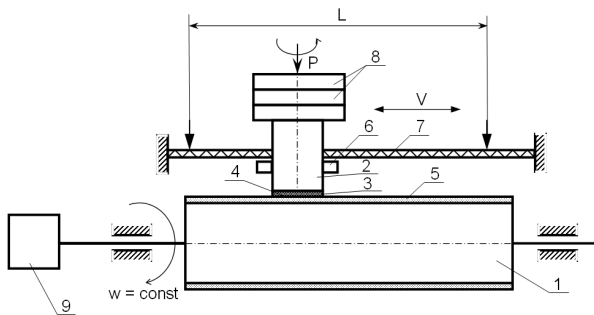

Figure 1: Functional scheme of the device for study of abrasive wear

The clamping device 6 consists of horizontal ring clutching with its external surface the immovable rack bar 7, which is parallel to the generatrix line of the drum 1. This ensures the relative translation of the specimen along the generatrix of the drum 1.

Central normal load is provided by the choice of the weights 8.

The fixed abrasive is presented by sandpaper fixed on the cylindrical surface of the drum. The drum rotates with constant angular speed. The relative motion of the specimen 2 is a plane motion: the nominal contact area translates on the generatrix of the drum and simultaneously rotates around the vertical axis passing through its center. The points of the contact zone have different velocities as value and direction in a given moment of time, changing periodically during the relative motion their position against the abrasive medium in the process of contact interaction.

That fact provides the uniform distribution of the wear in all points of the active surface of the specimen. Wear proceeds always on the new abrasive surface because of the rotation of the drum. A constant ratio exists between the angular velocities of the drum and the specimen.

The abrasive surface 5 is being cleaned from the waste of wear particles which are sucked by a vacuum pump through the appropriate nozzle. The rotation direction of the drum and the switching off the device are realized by the control unit 9.

The procedure includes determination of the following basic parameters:

- absolute linear wear h in $[\mu\text{m}]$ as difference between the coating thickness after and before passing a given friction path L_f :

- friction path calculated by the formula:

$$L_f = \sqrt{(2\pi r n t)^2 + L^2} \quad (1)$$

where: $r = 0,075$ [m] is the radius of the drum; $n = 40$ $[\text{min}^{-1}]$; $t = 2,28$ [min] - the time in which the specimen passes the length L of the generatrix of the drum;

- average sliding velocity V of the center of the contact area determined as follows (Fig. 2):

$$V_y = \omega r = \frac{\pi \cdot n}{30} r \quad (2)$$

$$V_x = \frac{L}{t} \quad (3)$$

$$V = \sqrt{V_y^2 + V_x^2} \quad (4)$$

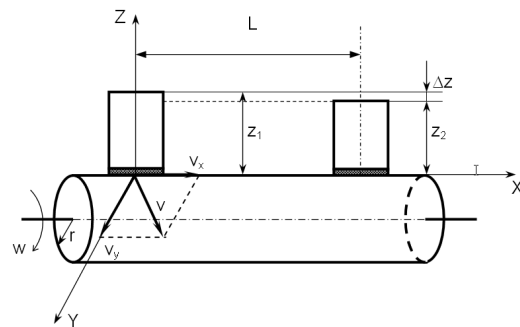

Figure 2: Sketch of the velocity of contact area center

- the linear wear intensity i is defined as linear wear in unit friction path:

$$i = h / L_f \quad (5)$$

- the wear-resistance I of the coating is defined as reciprocated value of the wear intensity:

$$I = \frac{1}{i} = \frac{L_f}{h} \quad (6)$$

- the coefficient of relative wear-resistance $\varepsilon_{i,o}$, expressing how much higher is the wear-resistance of a given coating I_i compared to the wear-resistance of a selected reference sample I_o under equal friction conditions; it is determined by the formula:

$$\varepsilon_{i,o} = \frac{I_i}{I_o} \quad (7)$$

The present study uses specimen without coating (№ 0 in Table 2) as reference sample.

The investigation is carried out under equal experimental conditions shown in Table 4.

Table 4 Parameters of wear resistance experiments

Normal contact pressure	$P_a = 23,2 \text{ N/cm}^2$
Average sliding speed	$V = 0,41 \text{ m/min}$
Abrasive material	Smirdex 330 Duroflex, P 80

3. Results and discussion

Experimental results have been obtained for the parameters wear, wear intensity and wear-resistance of all specimens – without and with coating as relationship to the friction path (time duration of friction).

Figure 3 shows graphical diagram of the linear wear with the friction path for all specimens.

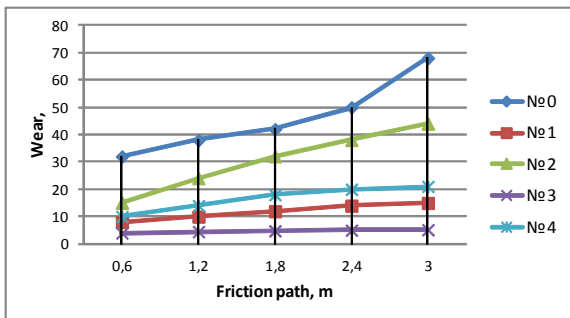

Figure 3: Wear versus friction path

Fig. 4 and Fig. 5 show correspondingly the diagrams of wear intensity and wear-resistance of all specimens for one and the same friction path $L_f = 3$ [m].

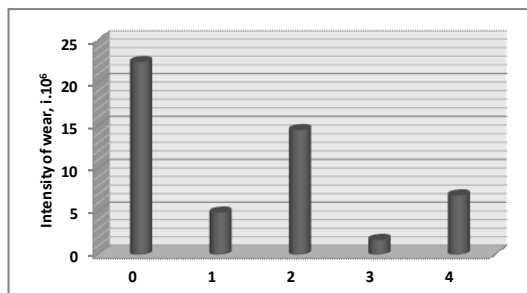

Figure 4: Chart of wear intensity

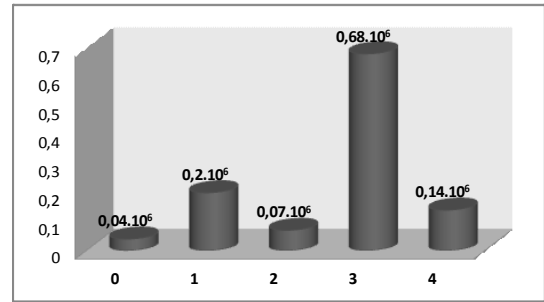

Figure 5: Chart of wear resistances

Table 3 gives the values for the coefficient of relative wear-resistance $\epsilon_{i,0}$ determined by the formula (7).

Table 3 Comparative wear resistance of the specimens

Comparative wear resistance, $\epsilon_{i,e}$			
$\epsilon_{1,0}$	$\epsilon_{2,0}$	$\epsilon_{3,0}$	$\epsilon_{4,0}$
5	1,75	14,5	3,5

The analysis of the obtained results allows the conclusion of the following:

- All coatings deposited by means of the HVOF-technology show higher wear-resistance than the wear-resistance of a specimen without coating under conditions of dry friction against surface of fixed abrasive particles.

- Lowest wear-resistance shows the coating with iron matrix (№ 2), which also has the lowest hardness – 25-30 HRC. Its wear-resistance is 2,85 times lower than that of the coating with nickel matrix (№ 1); 8,28 times lower than the coating with the tungsten matrix (№ 3) и 2 times lower than the coating $\text{Al}_2\text{O}_3+\text{TiO}_2$ (№ 4).

- Highest wear-resistance shows the coating with tungsten matrix (№ 3), which is 14,5 times higher than that of the substrate (№ 0); it is 2,9 times higher than that of the coating with Ni matrix, and 4,14 times higher than that of the coating $\text{Al}_2\text{O}_3+\text{TiO}_2$.

It should be assumed that the huge differences in the wear-resistance under abrasion conditions is due to the complex combination of high hardness of the tungsten carbides and the plasticity of cobalt compounds formed in the process of the coating deposition.

- The variation of wear with the friction path (the time duration) for all specimens shows nonlinear character with the exception of the most wear-resistant coating with tungsten matrix (Fig. 3).

4. Conclusions

The paper presents study and experimental results of the abrasive wear and wear-resistance of coatings deposited by the HVOF technology using powder

compositions with matrices of Fe, Ni, W and $\text{Al}_2\text{O}_3+\text{TiO}_2$.

Non-linear relationship has been established between the average wear and the friction path (time duration). An exception is observed for coatings with tungsten matrix which have shown the highest wear-resistance under conditions of abrasive wear compared with all other studied coatings.

The fact has been confirmed that the wear-resistance of coatings is not a constant value with the time duration of friction and wear maintaining equal other parameters – nominal contact pressure, sliding velocity, and parameters of the environment. This can be explained with the variation of the number of contact spots depending on the presence of different components in the composite coating under regimes of running-in and stationary friction.

It is necessary that a more accurate procedure and study are developed for the investigation of wear-resistance of the composite coatings taking into account the spatial and temporary distribution of the wear, the structure and composition of the coatings.

It may be safely said that under conditions of abrasive wear the HVOF-coatings obtained by powder compositions with tungsten matrix show the highest wear-resistance.

5. Acknowledgements

A part of this study is connected with the tasks on the 7 FP Project „Acom In (Advanced Computing Innovations)” coordinated by the Institute of Information and Communication Technologies at the Bulgarian Academy of Sciences, and the other part is carried out under the Project BG051PO001-3.3.06-0046 in Manufacturing Engineering at the Technical University of Sofia on the topic: "Supporting the development of PhD students and young researchers in virtual engineering and industrial technologies".

6. References

- [1] Гаркунов Д. Н., “Триботехника: Износ и безызносность”, МСХА, Москва, 2001. Garkunov, D. N., “Tribotechnology: Wear and Wearlessness”, Editing house of the Russian Agricultural Academy, Moscow, 2011 (in Russian).
- [2] Kandeва M., Tonchev, N., Hristov, N., Assenova, E., “Tribological Study of Cladded Bimetallic Coatings”, Journal of the Balkan Tribological Association, vol. 15, № 4, 2009, 455-464.
- [3] Kralov I., P. Sinapov, I. Ignatov, K. Nedelchev, Friction Induced Vibrations of a Railway Wheel Considering Different Damping in the System, Journal of the Balkan Tribological Association, Vol.18, №4, pp. 512-519, 2012. (IF=0,23).
- [4] Schwetzke R., Kreye H., “Microstructure and Properties of Coatings and Tungsten Carbides Atomized by Different HVOF-systems”,

Proceeding of the International Conference on Thermal Spraying, Nice, France, 1998, 187-192.